

5066		LOC	DIST	REVISIONS				DATE	APPD
DF	DO	P	F	ZONE	LTR	DESCRIPTION			
				B		REDRAWN & REV PER DFO193 & R2827	JA	11-13-87	FB
				C		REV-ECN DF-1034	MC	2-10-88	-
				D		REV-ECN DF-3928	PY	1-28-91	AE

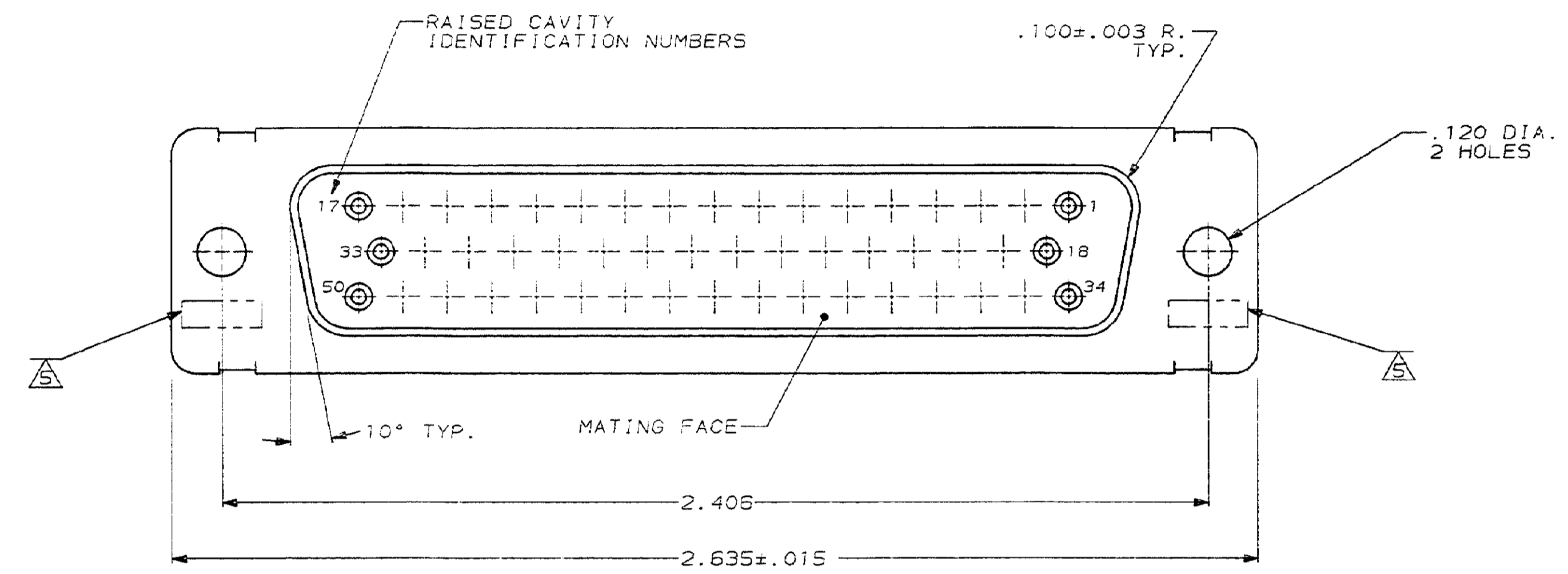

1. THIS RECEPTACLE WILL MATE WITH ANY 50 POSN., SIZE 5 PLUG IN THE AMPLIMITE SERIES.
  2. MAXIMUM WIRE INSULATION USED WITH THIS CONNECTOR IS .068 DIA.
  3. BE-CU RETENTION CLIPS ARE INCLUDED IN INSERT.
  4. CONNECTOR SUPPLIED WITHOUT CONTACTS; SHOWN FOR ILLUSTRATION ONLY.
- ▲ UL/CSA DESIGNATION STAMPED IN THIS AREA, OPTIONAL

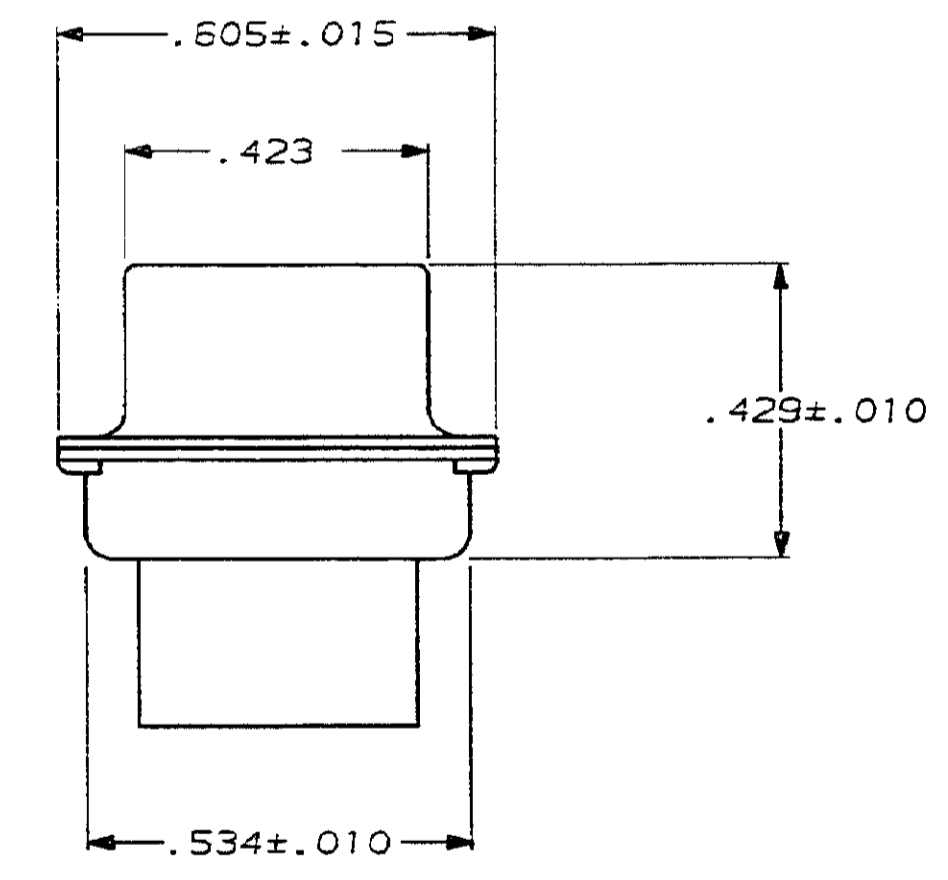
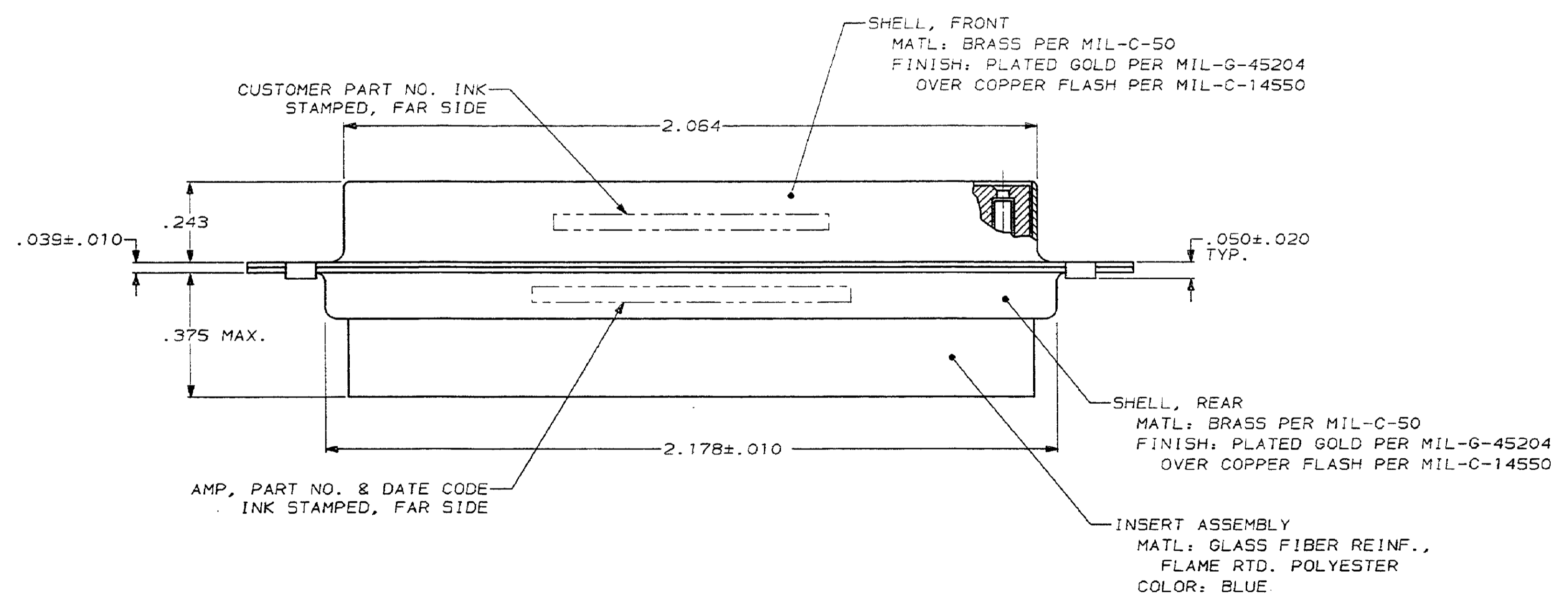

DO NOT SCALE PRINT. UNLESS SPECIFIED DIMENSIONS IN INCHES TOLERANCES ON:		DR	J. Shuy	11-13-87	AS SHOWN: WITH HUGHES P/N (1A01-005) INK STAMPED	211617-1
1 PLC DEC ± .005		CHK	11-30-87	F.C. BALLEW III	DESCRIPTION	PART NO
2 PLC DEC ± .005		APPD	11-30-87	F.C. BALLEW III	AMP INCORPORATED Morgantown, Pa. 17106	RECEPTACLE ASSEMBLY, AMPLIMITE 50 POSITION, SIZE 5, SERIES 109, NON-MAGNETIC
3 PLC DEC ± .005		APPD	11-30-87	D.J.M.		
ANGLES ± 0°30'		PRODUCT SPEC			NAME	
MATERIAL		APPLICATION SPEC			SIZE	FSCM NO
SEE CALLOUTS		WEIGHT			D	00779
FINISH				SCALE	DRAWING NO	211617
SEE CALLOUTS				4:1	SHEET	1 OF 1